

**General Description**

The AAT1185 is a single output step-down (Buck) regulator controller with an input range of 6V to 24V. The output range is adjustable from 0.8V to 5.5V.

The device provides high and low-side pins to drive external n-channel MOSFETs; allowing fully synchronous operation for maximum efficiency and performance. Alternately, the low-side MOSFET may be replaced with a Schottky rectifier. Both high and low-side drive pins are compatible with a wide range of external MOSFETs making the device the ideal control solution for low power and high power configurations.

Voltage mode control allows for optimum performance across the entire output voltage and load range. The 490kHz fixed switching frequency allows wide range of L/C filtering components, achieving smallest size and maximum efficiency. External compensation allows the designer to optimize the transient response.

The controller includes programmable over-current, integrated soft-start and over-temperature protection.

The AAT1185 is available in the Pb-free, 14-pin TSOPJW package. The rated operating temperature range is -40°C to 85°C.

**Features**

- $V_{IN}$  = 6.0V to 24.0V
- $V_{OUT}$  Adjustable from 0.8V to 5.5V
- $I_{OUT}$  from <1A up to 10A
- Small Solution Size
- Ultra-small External L/C
- Synchronous or Non-Synchronous
- Shutdown Current <30 $\mu$ A
- High Switching Frequency
- Voltage Mode Control
- PWM Fixed Frequency for Lowest Noise
  - Programmable Over-Current Protection
- Over-Temperature Protection
- Internal Soft Start
- 2.85x3mm TSOPJW-14 Package
- -40°C to 85°C Temperature Range

**Applications**

- DSL and Cable Modems
- Notebook Computers
- Satellite Set Top Boxes
- Wireless LAN Systems

**Typical Application**

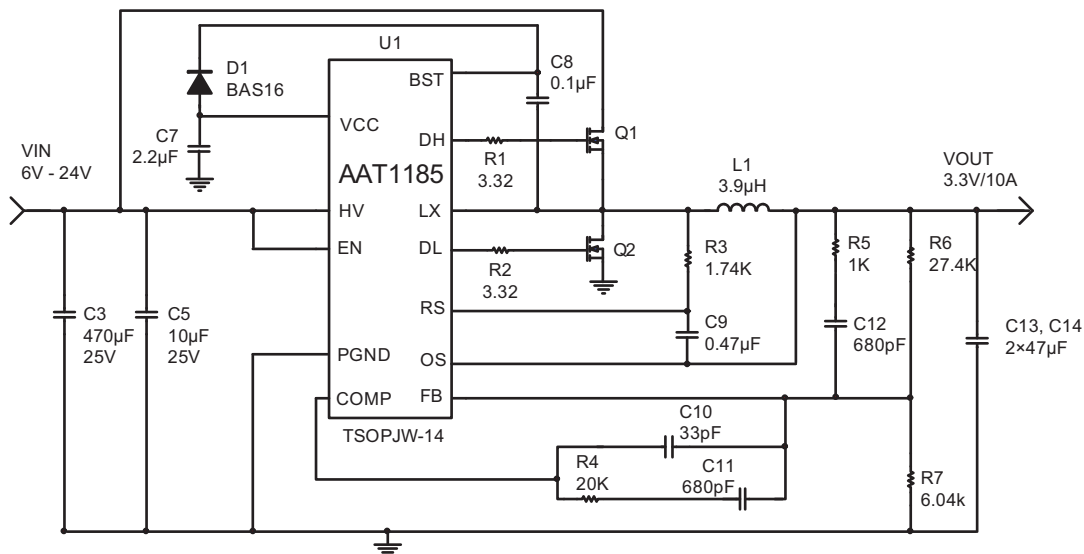

**High Voltage Step-Down Controller****Pin Descriptions**

Pin #	Symbol	Function	Description
1	RS	I	Output sense voltage pin. Connect to the output capacitor to enable over-current sense for step-down converter.
2	OS	I	Output current sense pin. Connect a small signal resistor from this pin to small signal resistor which is tied to switching node (LX) to enable over-current sense for step-down converter. The current limit threshold varies with inductor parasitic winding resistance ( $R_{DC(L)}$ ); see the Applications Information section of this datasheet for details.
3	EN	I	Step-down regulator enable input pin. Active high or tied to high voltage input (IN) enables internal linear regulator and output.
4	BST	I	Step-down regulator boost drive input pin. Connect the cathode of fast rectifier from this pin and connect a 100nF capacitor from this pin to the switching node (LX) to provide drive to external hi-side MOSFET gate.
5	DH	O	High side driver for external high side n-channel MOSFET. Connect this pin to gate of external high side n-channel MOSFET device.
6	LX	O	Step-down converter switching pin. Connect output inductor to this pin.
7	PGND	GND	Power ground pin for step-down regulator. When using synchronous option, tie to PCB ground plane near source pins of external low-side MOSFET(s).
8	DL	O	Low side driver for external low side n-channel MOSFET. When using synchronous option, connect this pin to gate of external low side n-channel MOSFET device. Otherwise, leave pin open.
9, 11	VL	I/O	Internal linear regulator for step-down converter. Connect a 2.2 $\mu$ F/6.3V capacitor from this pin to GND.
10	IN	I	High voltage input pin.
12	GND	GND	Ground pin for step-down regulator. Tie to PCB ground plane.
13	FB	I	Feedback input pin for step-down converter. Connect an external resistor divider to this pin to program the output voltage to the desired value.
14	COMP	I	Compensation pin for step-down converter. Connect a resistor, capacitor network to compensate the voltage mode control loop.

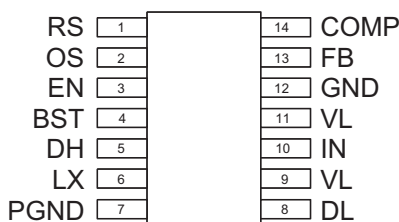
**Pin Configuration****TSOPJW-14  
(Top View)**

**High Voltage Step-Down Controller****Absolute Maximum Ratings<sup>1</sup>**

$T_A = 25^\circ\text{C}$  unless otherwise noted.

Symbol	Description	Value	Units
$V_{IN(HI)}, V_{EN}$	IN, LX, EN to GND	-0.3 to 30.0	V
$V_{IN(LO)}$	VL to GND	-0.3 to 6.0	V
$V_{BST-LX}$	BST to LX	-0.3 to 6.0	V
$V_{CONTROL}$	DH, DL, FB, COMP, RS, OS to PGND, GND	-0.3 to $V_{IN(LO)} + 0.3$	V
$T_J$	Operating Junction Temperature Range	-40 to 150	$^\circ\text{C}$
$T_{LEAD}$	Maximum Soldering Temperature (at leads, 10 sec)	300	$^\circ\text{C}$

**Thermal Information<sup>2</sup>**

Symbol	Description	Value	Units
$\Theta_{JA}$	Thermal Resistance <sup>3</sup>	140	$^\circ\text{C}/\text{W}$
$P_D$	Maximum Power Dissipation	0.7	W

1. Stresses above those listed in Absolute Maximum Ratings may cause permanent damage to the device. Functional operation at conditions other than the operating conditions specified is not implied. Only one Absolute Maximum Rating should be applied at any one time.

2. Mounted on an FR4 board.

3. Derate 7mW/ $^\circ\text{C}$  above 25 $^\circ\text{C}$ .

**High Voltage Step-Down Controller****Electrical Characteristics<sup>1</sup>**

$V_{IN1} = 12.0V$ ;  $T_A = -40^{\circ}C$  to  $85^{\circ}C$  unless otherwise noted. Typical values are at  $T_A = 25^{\circ}C$ .

Symbol	Description	Conditions	Min	Typ	Max	Units
$V_{IN}$	Input Voltage		6.0		24.0	V
$V_{UVLO}$	UVLO Threshold	$V_{IN}$ Rising			5.0	V
		$V_{IN}$ Hysteresis		300		mV
		$V_{IN}$ Falling	3.0			V
$V_{OUT}$	Output Voltage Range		0.8		5.5	V
$V_{FB}$	Feedback Pin Voltage		0.591	0.600	0.609	V
$I_Q$	Quiescent Current	$V_{EN} = \text{High}$ , No load		1.0		mA
$I_{SHDN}$	Shutdown Current	$V_{EN} = \text{Low}$ , $V_L = 0V$			30	$\mu A$
$V_{OCP}$	Over-Current Offset Voltage	$V_{EN} = \text{High}$ , $V_{IN} = 6.0V$ to $24.0V$ , $T_A = 25^{\circ}C$	70	100	130	mV
$I_{LX}$	LX1 Pin Leakage Current	$V_{IN} = 24.0V$ , $V_{EN} = \text{Low}$	-1.0		1.0	$\mu A$
$D_{MAX}$	Maximum Duty Cycle			85		%
$T_{ON(MIN)}$	Minimum On-Time	$V_{IN} = 6.0V$ to $24.0V$		100		ns
$R_{DH}$	High Side Drive Source Resistance	Pull-Up		5.0		$\Omega$
		Pull-Down		1.7		
$R_{DL}$	Low Side Drive Source Resistance	Pull-Up		5.0		$\Omega$
		Pull-Down		1.7		
$F_{OSC}$	Oscillator Frequency		350	490	650	kHz
$F_{FOLDBACK}$	Short Circuit Foldback Frequency	Current Limit Triggered		100		kHz
$T_S$	Start-Up Time	From Enable to Output Regulation		2.5		ms
$T_{SD}$	Over-Temperature Shutdown Threshold			135		$^{\circ}C$
	Over-Temperature Shutdown Hysteresis			15		$^{\circ}C$
$V_{EN(L)}$	Enable Threshold Low				0.6	V
$V_{EN(H)}$	Enable Threshold High		2.5			V
$I_{EN}$	Input Low Current		-1.0		1.0	$\mu A$

1. The AAT1185 is guaranteed to meet performance specifications over the  $-40^{\circ}C$  to  $+85^{\circ}C$  operating temperature range and is assured by design, characterization and correlation with statistical process controls.

### Typical Characteristics

Circuit of Figure 4, unless otherwise specified.

**Step-Down Controller Efficiency vs. Load**  
( $V_{OUT} = 3.3V$ ;  $L = 3.9\mu H$ )

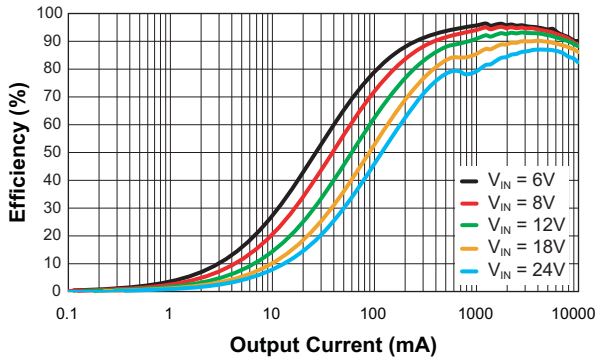

**Step-Down Controller DC Regulation**  
( $V_{OUT} = 3.3V$ ;  $L = 3.9\mu H$ )

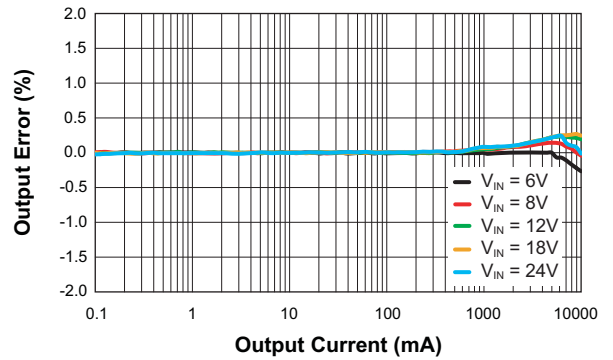

**Step-Down Controller Line Regulation**  
( $V_{OUT} = 3.3V$ ;  $L = 3.9\mu H$ )

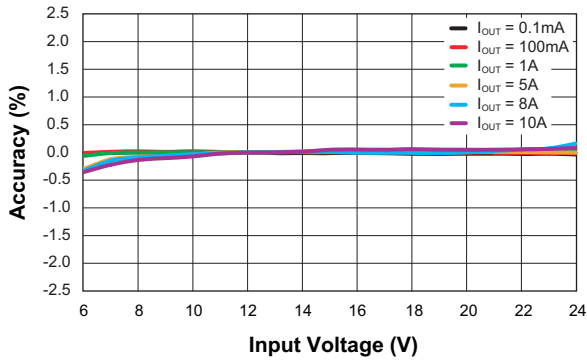

**Step-Down Controller Output Voltage Error vs. Temperature**  
( $V_{IN} = 12V$ ;  $V_{OUT} = 3.3V$ )

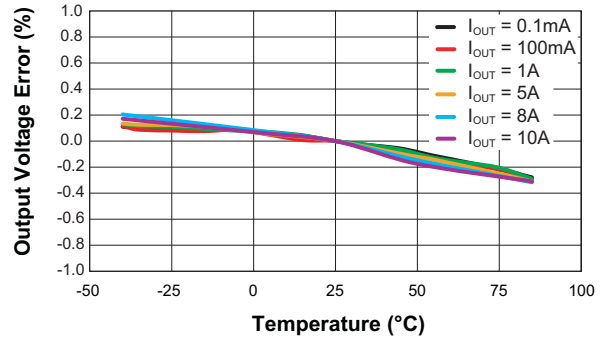

**Step-Down Controller Output Ripple**  
( $V_{IN} = 12V$ ;  $V_{OUT} = 3.3V$ ;  $I_{OUT} = 1mA$ )

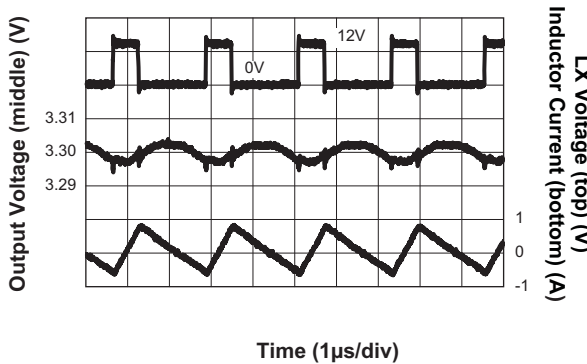

**Step-Down Controller Output Ripple**  
( $V_{IN} = 12V$ ;  $V_{OUT} = 3.3V$ ;  $I_{OUT} = 10A$ )

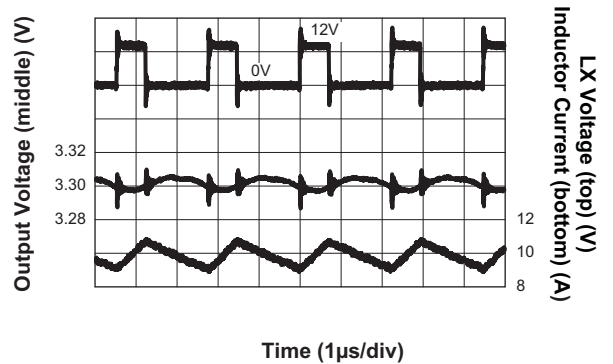

### Typical Characteristics

Circuit of Figure 4, unless otherwise specified.

**Step-Down Controller Load Transient Response**  
( $V_{IN} = 12V$ ;  $I_{OUT} = 1A$  to  $10A$ ;  $C_{OUT} = 2x47\mu F$ )

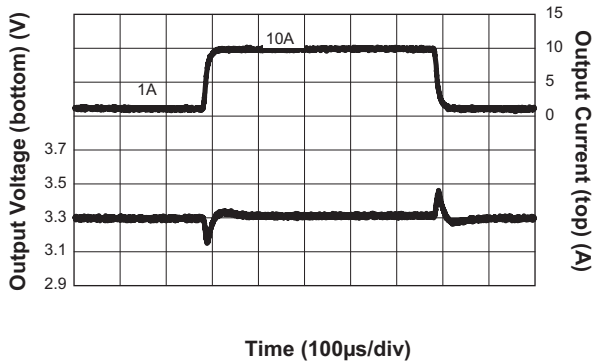

**Step-Down Controller Load Transient Response**  
( $V_{IN} = 12V$ ;  $I_{OUT} = 5A$  to  $10A$ ;  $C_{OUT} = 2x47\mu F$ )

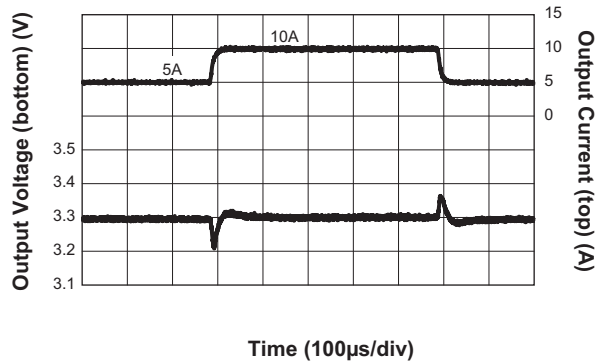

**Step-Down Controller Load Transient Response**  
( $V_{IN} = 12V$ ;  $I_{OUT} = 7.5A$  to  $10A$ ;  $C_{OUT} = 2x47\mu F$ )

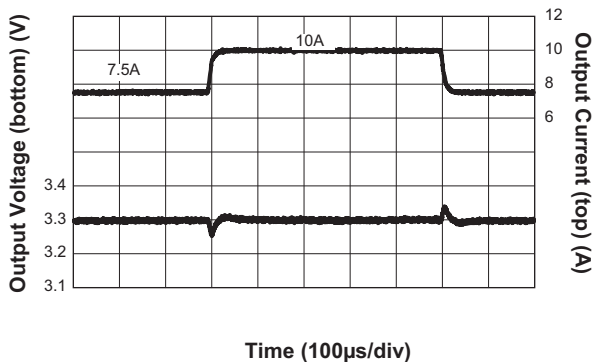

**Step-Down Controller Soft Start**  
( $V_{IN} = 12V$ ;  $V_{OUT} = 3.3V$ ;  $I_{OUT} = 10A$ )

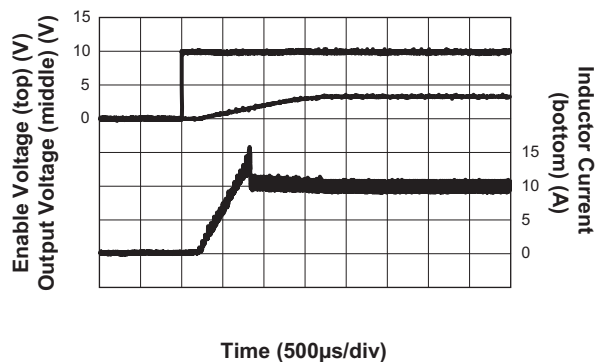

**Step-Down Controller Line Transient Response**  
( $V_{IN} = 8V$  to  $12V$ ;  $V_{OUT} = 3.3V$ ;  $I_{OUT} = 5A$ )

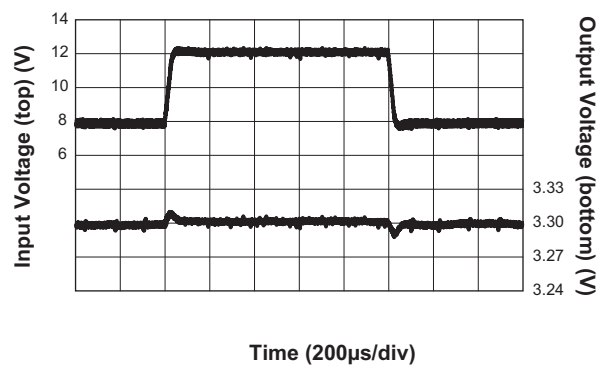

**Step-Down Controller Line Transient Response**  
( $V_{IN} = 8V$  to  $12V$ ;  $V_{OUT} = 3.3V$ ;  $I_{OUT} = 10A$ )

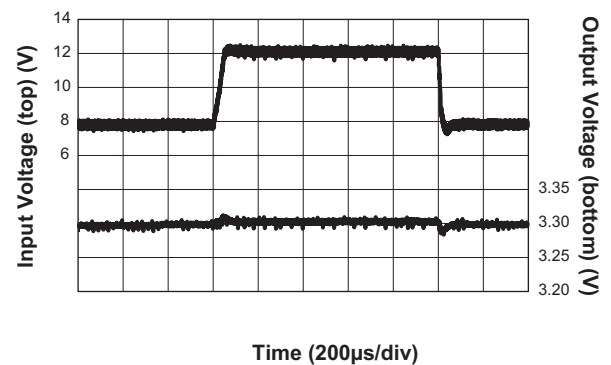

### Typical Characteristics

Circuit of Figure 4, unless otherwise specified.

**Step-Down Controller Switching Frequency vs. Input Voltage**  
( $V_{OUT} = 3.3V$ ;  $I_{OUT} = 10A$ )

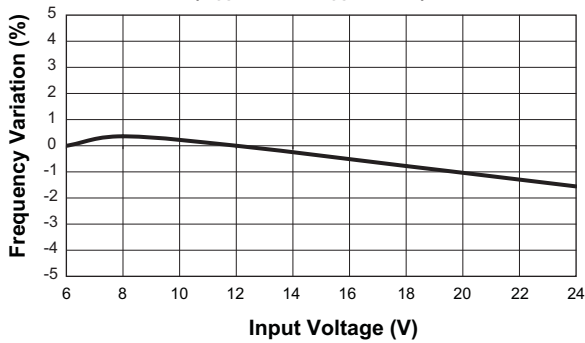

**Step-Down Controller Switching Frequency vs. Temperature**  
( $V_{IN} = 12V$ ;  $V_{OUT} = 3.3V$ ;  $I_{OUT} = 10A$ )

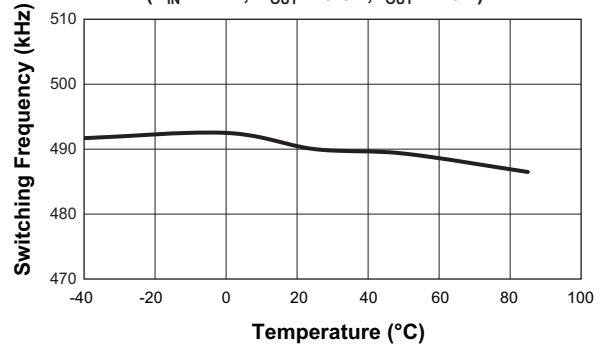

**No Load Step-Down Controller Input Current vs. Input Voltage**  
( $V_{EN} = V_{IN}$ )

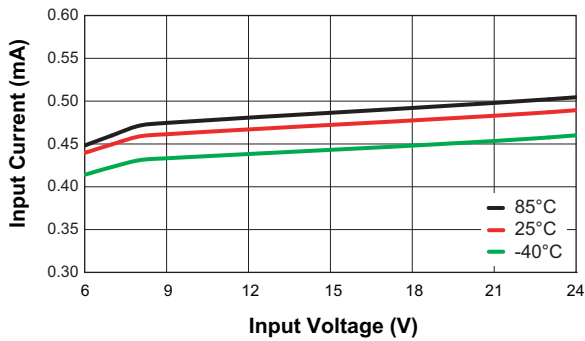

**Step-Down Controller Current Limit**  
( $V_{IN} = 12V$ ;  $V_{OUT} = 3.3V$ ;  $L = 3.9\mu H$ )

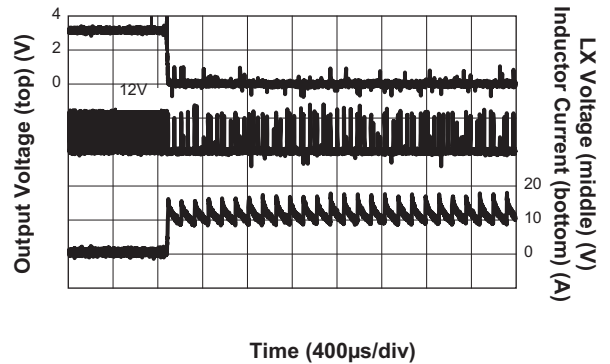

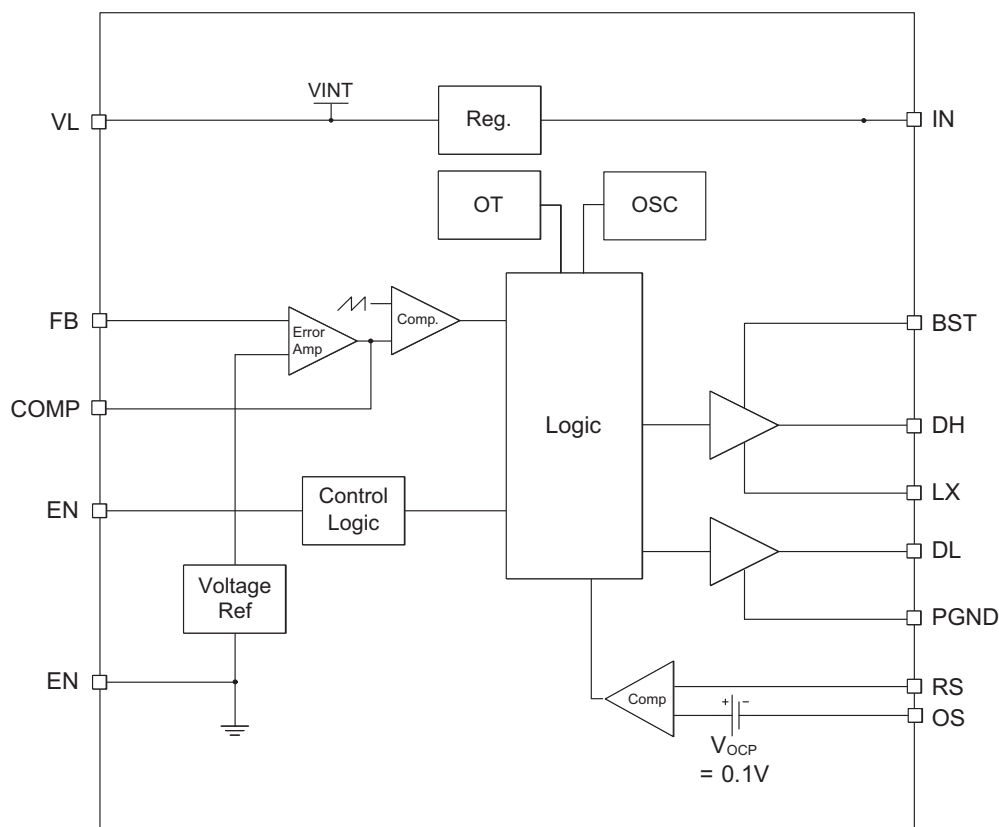
**Functional Block Diagram****Applications Information**

The AAT1185 is a single output step-down (Buck) regulator controller with an input range of 6V to 24V. The output range is adjustable from 0.8V to 5.5V.

The device provides high and low-side pins to drive external n-channel MOSFETs; allowing fully synchronous operation for maximum efficiency and performance. Alternatively, the low-side MOSFET may be replaced with a Schottky rectifier and the DL pin left open. Both high and low-side drive pins are compatible with a wide range of external MOSFETs making the device the ideal control solution for low power and high power configurations.

Voltage mode control allows for optimum performance across the entire output voltage and load range. 490kHz fixed switching frequency allows wide range of L/C filtering components, achieving smallest size and maximum efficiency. External compensation allows the designer to optimize the transient response components.

The controller includes programmable over-current, integrated soft-start and over-temperature protection.

The AAT1185 is available in the Pb-free, 14-pin TSOPJW package. The rated operating temperature range is -40°C to 85°C.

**Regulator Output Capacitor Selection**

Two 47 $\mu$ F ceramic output capacitors are required to filter the inductor current ripple and supply the load transient current for  $I_{OUT} = 10A$ . The 1210 package with 10V minimum voltage rating is recommended for the output capacitors to maintain a minimum capacitance drop with DC bias.

**Output Inductor Selection**

The step-down converter utilizes constant frequency (PWM-mode) voltage mode control. A 3.9 $\mu$ H to 4.7 $\mu$ H inductor value with appropriate DCR is selected to maintain the desired output current ripple and minimize the



## High Voltage Step-Down Controller

converter's response time to load transients. The peak switch current should not exceed the inductor saturation current of the MOSFETs. The DCR of the inductor sets the designed current limit in the following formula:

$$I_{LIM} = \frac{100mV}{DCR}$$

For 10A output load, the selected DCR should be less than 10mΩ to avoid the peak inductor current triggers the current limit.

### MOSFET Selection

The step-down (buck) converter utilizes synchronous rectification (Q1) for constant frequency (PWM mode) voltage mode control. The synchronous rectifier is selected based on the desired  $R_{DS(ON)}$  value and  $Q_G$  (total gate charge), these two critical parameters are weighed against each other. To get a low  $R_{DS(ON)}$  value, the MOSFET must be very large; a larger MOSFET will have a large  $Q_G$ . Conversely, to get a low  $Q_G$ , the MOSFET must be small and thus have a large  $R_{DS(ON)}$  value. In addition to the trade off between  $R_{DS(ON)}$  and  $Q_G$ , the maximum voltage rating for the external synchronous MOSFET must exceed the maximum application input voltage value ( $V_{DS} [max] > V_{IN} [max]$ ).

The  $Q_G$  affects the turn-on/turn-off time of the synchronous MOSFET; the longer the turn-on/turn-off time, the more likely the step-down converter will have "shoot-through" current issues. "Shoot-through" current occurs when the high-side MOSFET and the low-side MOSFET are conducting current at the same time. This will result in a low impedance path to ground from the input voltage through the two MOSFETs, and the current may exceed the maximum current rating of the MOSFETs. Exceeding the maximum current ratings will lead to the destructive derating of the MOSFETs.

The critical parameter recommendations for the external minimum 25V MOSFET are as follows:

$Q_G$  (Total Gate Charge): 5nC to 15nC (max)

( $V_{GS}$ : 4.5V to 5V)

$R_{DS(ON)}$ : 10mΩ to 30mΩ (max) ( $V_{GS}$ : 4.5V to 5V)

### Input Capacitor Selection

For low-cost applications, a 470μF/25V electrolytic capacitor is selected to control the voltage overshoot across the high side MOSFET. A 10μF/25V ceramic capacitor with a voltage rating at least 1.05 times greater than the maximum input voltage is connected as close

as possible to the input pins (Pins 9 and 11) for high frequency decoupling.

### Feedback and Compensation Networks

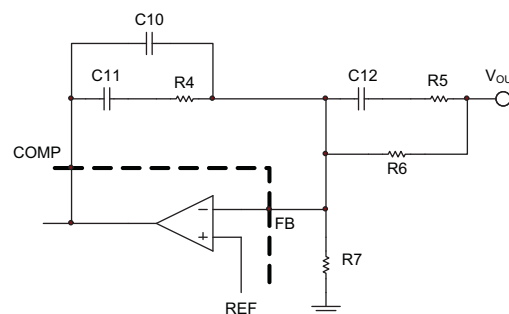

**Figure 1: AAT1185 Feedback and Compensation Networks for Type III Voltage-Mode Control Loop.**

The transfer function of the error amplifier is dominated by DC gain and the  $L C_{OUT}$  output filter of the regulator. This output filter and its equivalent series resistance (ESR) create a double pole at  $F_{LC}$  and a zero at  $F_{ESR}$  in the following equations:

$$\text{Eq. 1: } F_{LC} = \frac{1}{2 \cdot \pi \cdot \sqrt{L} \cdot C_{OUT}}$$

$$\text{Eq. 2: } F_{ESR} = \frac{1}{2 \cdot \pi \cdot ESR \cdot C_{OUT}}$$

The feedback and compensation networks provide a closed loop transfer function with the highest 0dB crossing frequency and adequate phase margin for system stability. Equations 3, 4, 5 and 6 relate the compensation network's poles and zeros to the components  $R_4$ ,  $R_5$ ,  $R_6$ ,  $C_{10}$ ,  $C_{11}$ , and  $C_{12}$ :

$$\text{Eq. 3: } F_{Z1} = \frac{1}{2 \cdot \pi \cdot R_4 \cdot C_{11}}$$

$$\text{Eq. 4: } F_{Z2} = \frac{1}{2 \cdot \pi \cdot (R_5 + R_6) \cdot C_{12}}$$

$$\text{Eq. 5: } F_{P1} = \frac{1}{2 \cdot \pi \cdot R_4 \cdot \left( \frac{C_{10} \cdot C_{11}}{C_{10} + C_{11}} \right)}$$

$$\text{Eq. 6: } F_{P2} = \frac{1}{2 \cdot \pi \cdot R_5 \cdot C_{12}}$$

Components of the feedback, feed-forward, and compensation networks need to be adjusted to maintain the system's stability for different input and output voltages applications as shown in Table 1.

Network	Components	$V_{OUT} = 3.3V$ $V_{IN} = 6V-24V$	$V_{OUT} = 5.0V$ $V_{IN} = 6V-24V$
Feedback	R <sub>6</sub>	27.4kΩ	1.96kΩ
	R <sub>7</sub>	6.04kΩ	14.3kΩ
Feed-forward	C <sub>12</sub>	680pF	2.2nF
	R <sub>5</sub>	1kΩ	453Ω
Compensation	C <sub>10</sub>	33pF	2.2nF
	C <sub>11</sub>	680pF	150pF
	R <sub>4</sub>	20kΩ	3.92kΩ

**Table 1: AAT1185 Feedback and Compensation Components for  $V_{OUT} = 3.3V$  and  $V_{OUT} = 5.0V$ .**

### Over-Current Protection

The controller provides true-load DC output current sensing which protects the load and limits component stresses. The output current is sensed through the DC resistance in the output inductor (DCR). The controller reduces the operating frequency when an over-current condition is detected; limiting stresses and preventing inductor saturation. This allows the smallest possible inductor for a given output load. A small resistor divider may be necessary to adjust the over-current threshold and compensate for variation in inductor DCR. The pre-set current limit threshold is triggered when the differential voltage from RS to OS exceeds 100mV (nominal).

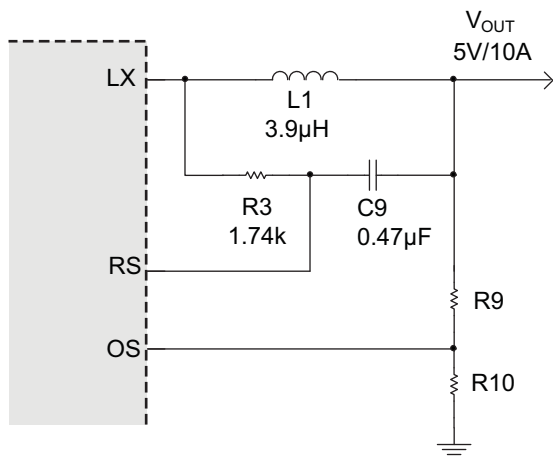

**Figure 2: Resistor Network to Adjust the Current Limit Less than the Pre-Set Over-Current Threshold (Add R9, R10).**

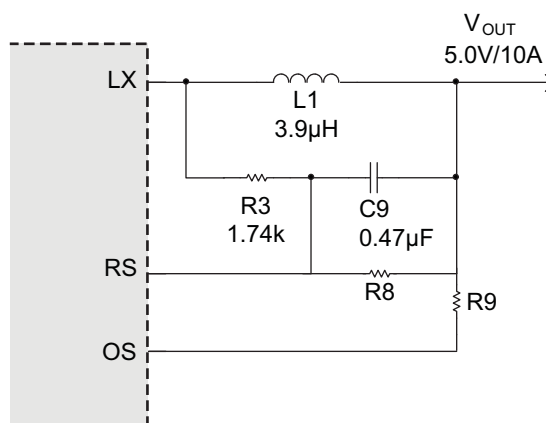

**Figure 3: Resistor Network to Adjust the Current Limit Greater than the Pre-Set Over-Current Threshold (Add R8, R9).**

L1 (µH)	R3 (kΩ)	C9 (µF)	Part Number
3.9	1.74	0.47	B82559A0392A013, 3.9µH, Epcos, $I_{SAT} = 12A$ , DCR = 4.8mΩ
4.2	2	0.47	RLF12560T-4R2N100, 4.2µH, TDK, $I_{SAT} = 10.2A$ , DCR = 7.4mΩ
4.7	1.47	0.47	SER2013-472ML, 4.7µH, Coilcraft, $I_{SAT} = 18A$ , DCR = 1.7mΩ

**Table 2: Current Limit Network vs. Inductor DCR.**

### Thermal Protection

The AAT1185 has an internal thermal protection circuit which will turn on when the device die temperature exceeds 135°C. The internal thermal protection circuit will actively turn off the high side regulator output device to prevent the possibility of over temperature damage.

**High Voltage Step-Down Controller**

The Buck regulator output will remain in a shutdown state until the internal die temperature falls back below the 135°C trip point. The combination and interaction between the short circuit and thermal protection systems allows the Buck regulator to withstand indefinite short-circuit conditions without sustaining permanent damage.

**Thermal Calculations**

There are three types of losses associated with the AAT1185 step-down converter: switching losses, conduction losses, and quiescent current losses. Conduction losses are associated with the  $R_{DS(ON)}$  characteristics of the power output switching devices. Switching losses are dominated by the gate charge of the power output switching devices. At full load, assuming continuous conduction mode (CCM), a simplified form of the synchronous step-down converter and LDO losses is given by:

$$P_{TOTAL} = \frac{I_{OUT}^2 \cdot (R_{DS(ON)H} \cdot V_{OUT} + R_{DS(ON)L} \cdot [V_{IN} - V_{OUT}])}{V_{IN}} + (t_{SW} \cdot F_S \cdot I_{OUT} + I_Q) \cdot V_{IN}$$

$I_{Q1}$  is the step-down converter quiescent currents. The term  $t_{SW}$  is used to estimate the full load step-down converter switching losses.

The power dissipation that relates to the  $R_{DS(ON)}$  occurs in the external high side and low side MOSFETs. Therefore, the total package losses for AAT1185 reduce to the following equation:

$$P_{TOTAL} = (t_{SW} \cdot F_S \cdot I_{OUT} + I_{Q1}) \cdot V_{IN1}$$

Since quiescent current, and switching losses all vary with input voltage, the total losses should be investigated over the complete input voltage range.

Given the total losses, the maximum junction temperature can be derived from the  $\theta_{JA}$  for the TSOPJW-14 package, which is 140°C/W.

$$T_{J(MAX)} = P_{TOTAL} \cdot \theta_{JA} + T_{AMB}$$

**Layout Considerations**

The suggested PCB layout for the AAT1185 is shown in Figures 5, 6, 7, and 8. The following guidelines should be used to help ensure a proper layout.

1. The power input capacitors (C3 and C5) should be connected as closely as possible to the high voltage input pin (IN) and power ground.
2. C5, L1, Q1, C13, and C14 should be placed as close as possible to each other to minimize any parasitic inductance in the switched current path, which generates a large voltage spike during the switching interval. The connection of inductor to switching node should be as short as possible.
3. The feedback trace or FB pin should be separated from any power trace and connected as closely as possible to the load point. Sensing along a high-current load trace will degrade DC load regulation.
4. The resistance of the trace from the load returns to PGND should be kept to a minimum. This will help to minimize any error in DC regulation due to differences in the potential of the internal signal ground and the power ground.
5. Connect unused signal pins to ground to avoid unwanted noise coupling.
6. The critical small signal components, include feedback components and compensation components, should be placed close to the FB1 and COMP1 pins. The feedback resistors should be located as close as possible to the FB1 pin with its ground tied straight to the signal ground plane, which is separated from the power ground plane.
7. C9 and R3 should be connected as closely as possible to the RS1 and OS1 pins and placed on the bottom side of the layout to avoid noise coupling from the inductor.
8. For good thermal coupling, a 4-layer PCB layout is recommended and PCB vias are required from the exposed pad (EP) for the MOSFETs paddle to the middle plane and bottom plane.

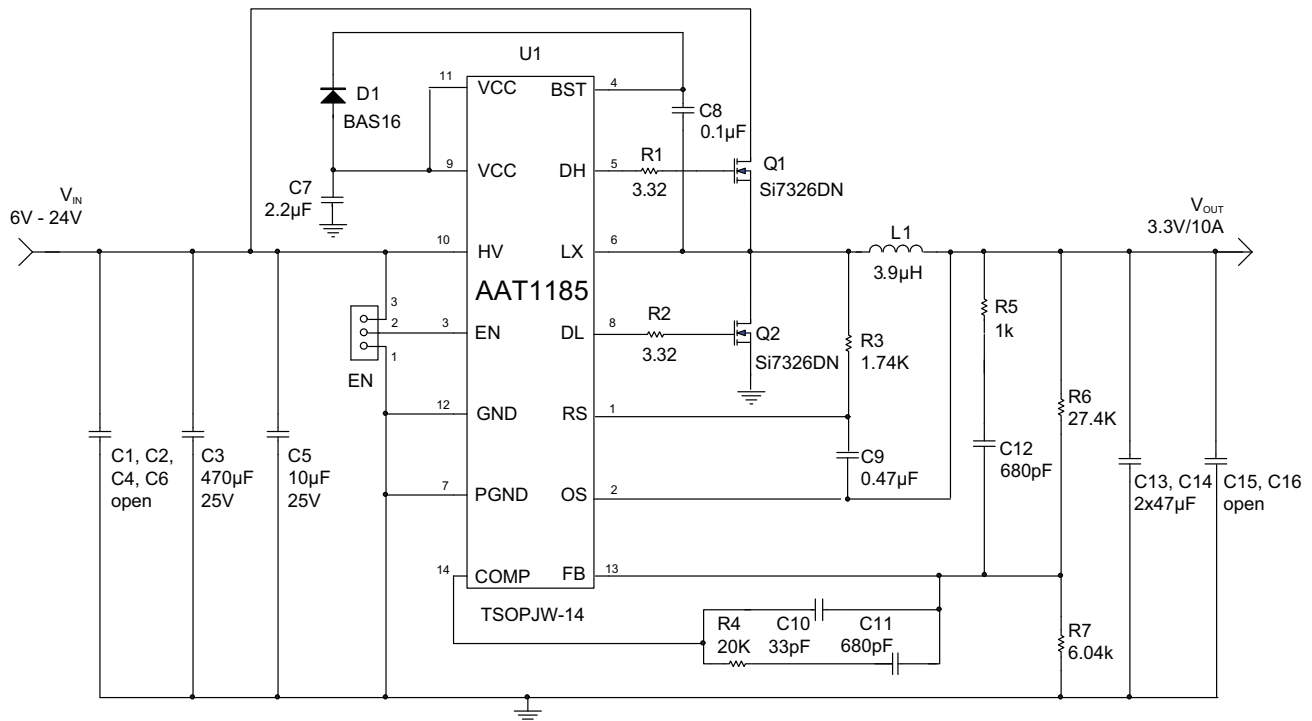
**AAT1185****High Voltage Step-Down Controller**

U1	AAT1185 Skyworks, Hi-Voltage Buck Controller, TSOPJW-14
C3	Cap, MLC, 470µF/25V, Electrolytic
C5	Cap, MLC, 10µF/25V, 1210
C7	Cap, MLC, 2.2µF/6.3V, 0603
C8	Cap, MLC, 0.1µF/6.3V, 0603
C9	Cap, MLC, 0.47µF/6.3V, 0603
C10, C11, C12	Cap, MLC, misc, 0402
C13, C14	Cap, MLC, 47µF/10V, 1210
R1-R7	Carbon film resistor, 0402
D1	BAS16, Generic, Rectifier, 0.2A/85V, Ultrafast, SOT23
Q1, Q2	Si7326DN, Vishay, N-Channel, 30V, 10A, PAK 1212-8
L1	B82559A0392A013, 3.9µH, Epcos, I <sub>SAT</sub> = 12A, DCR = 4.8mΩ
L1	RLF12560T-4R2N100, 4.2µH, TDK, I <sub>SAT</sub> = 10.2A, DCR = 7.4mΩ
L1	SER2013-472ML, 4.7µH, Coicraft, I <sub>SAT</sub> = 18A, DCR = 1.7mΩ

**Figure 4: AAT1185ITO Evaluation Board Schematic for  $V_{IN} = 6V-24V$  and  $V_{OUT} = 3.3V$ .**

# AAT1185

## High Voltage Step-Down Controller

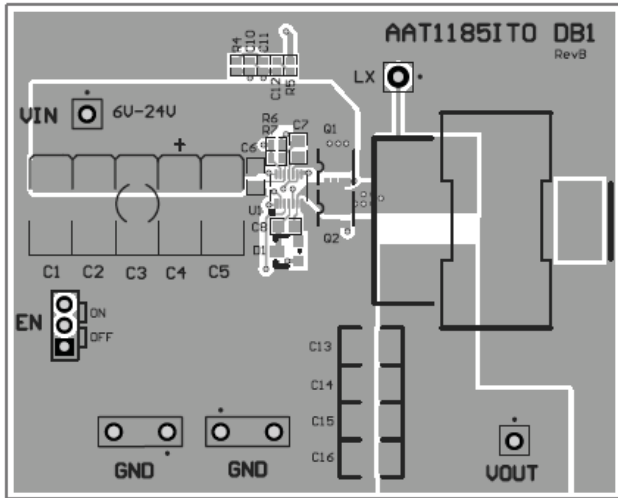

Figure 5: AAT1185ITO Evaluation Board Top Layer.

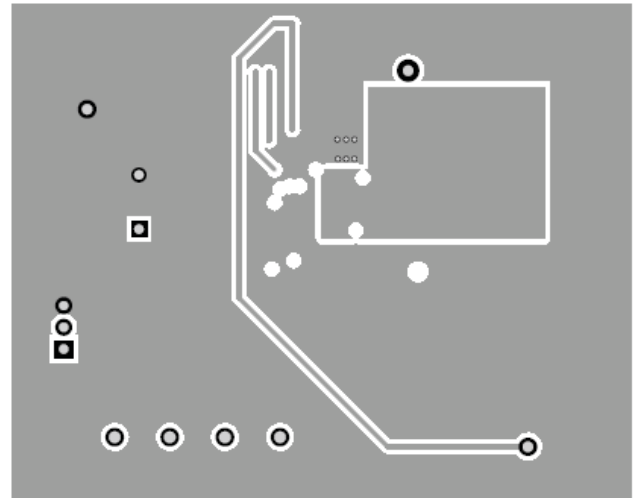

Figure 6: AAT1185ITO Evaluation Board MID1 Layer.

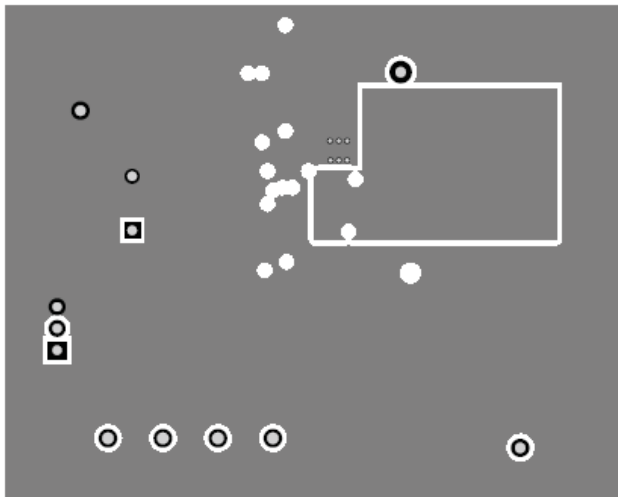

Figure 7: AAT1185ITO Evaluation Board MID2 Layer.

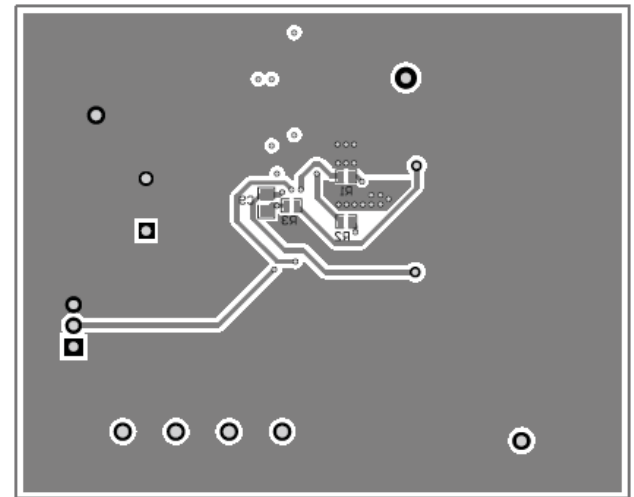

Figure 8: AAT1185ITO Evaluation Board Bottom Layer

**AAT1185 Design Example****Specifications**

$V_O = 3.3V @ 10A$ , Pulsed Load  $\Delta I_{LOAD} = 10A$

$V_{IN} = 12V$

$F_S = 490kHz$

$T_{AMB} = 85^\circ C$  in TSOPJW-14 Package

**Output Inductor**

For Epcos inductor B82559A0392A013,  $3.9\mu H$ , DCR =  $4.8m\Omega$  max.

$$\Delta I = \frac{V_{OUT}}{L_1 \cdot F_S} \cdot \left(1 - \frac{V_{OUT}}{V_{IN}}\right) = \frac{3.3V}{3.9\mu H \cdot 490kHz} \cdot \left(1 - \frac{3.3V}{12V}\right) = 1.25A$$

$$I_{PK1} = I_{OUT1} + \frac{\Delta I}{2} = 10A + 0.6A = 10.6A$$

$$P_{L1} = I_{OUT1}^2 \cdot DCR = 10.6A^2 \cdot 4.8m\Omega = 539mW$$

**Output Capacitor**

$V_{DROOP} = 0.6V$

$$C_{OUT} = \frac{3 \cdot \Delta I_{LOAD}}{V_{DROOP} \cdot F_S} = \frac{3 \cdot 10A}{0.6V \cdot 490kHz} = 102\mu F; \text{ use } 2 \times 47\mu F$$

$$I_{RMS(MAX)} = \frac{1}{2 \cdot \sqrt{3}} \cdot \frac{V_{OUT} \cdot (V_{IN(MAX)} - V_{OUT})}{L \cdot F_S \cdot V_{IN(MAX)}} = \frac{1}{2 \cdot \sqrt{3}} \cdot \frac{3.3V \cdot (24V - 3.3V)}{3.9\mu H \cdot 490kHz \cdot 24V} = 430mA_{RMS}$$

$$P_{RMS} = ESR \cdot I_{RMS}^2 = 5m\Omega \cdot (430mA)^2 = 0.9mW$$

**Input Capacitor**

Input Ripple  $V_{PP} = 60mV$

$$C_{IN} = \frac{1}{\left(\frac{V_{PP}}{I_{OUT}} - ESR\right) \cdot 4 \cdot F_S} = \frac{1}{\left(\frac{60mV}{10A} - 5m\Omega\right) \cdot 4 \cdot 490kHz} = 510\mu F$$

For low cost applications, a  $470\mu F/25V$  electrolytic capacitor in parallel with a  $10\mu F/25V$  ceramic capacitor is used to reduce the ESR.

$$I_{RMS} = \frac{I_{OUT1}}{2} = 5A$$

$$P = ESR \cdot (I_{RMS})^2 = 5m\Omega \cdot (5A)^2 = 125mW$$

**Current Limit**

Over-current offset voltage  $V_{OCP} = 100\text{mV}$

Total trace parasitic resistor and inductor DCR is  $6\text{m}\Omega$

$$I_{LIMIT} = \frac{V_S}{DCR} = \frac{100\text{mV}}{6\text{m}\Omega} = 17\text{A}$$

In order to sense the inductor current correctly during dynamic operation the R-C network time constant  $R_3 \cdot C_9$  should match the inductor time constant  $L_1/DCR$ :

$$\frac{L_1}{DCR} = R_3 \cdot C_9$$

Choose  $C_9 = 0.47\mu\text{F}$

$$R_3 = \frac{L_1}{DCR \cdot C_9} = \frac{3.9\mu\text{H}}{4.8\text{m}\Omega \cdot 0.47\mu\text{F}} = 1.74\text{k}\Omega$$

**AAT1185 Losses**

All values assume  $25^\circ\text{C}$  ambient temperature and thermal resistance of  $140^\circ\text{C/W}$  in the TSOPJW-12 package.

$$P_{TOTAL} = (t_{SW} \cdot F_S \cdot I_{OUT1} + I_Q) \cdot V_{IN}$$

$$P_{TOTAL} = (5\text{ns} \cdot 490\text{kHz} \cdot 10\text{A} + 70\mu\text{A}) \cdot 12\text{V}$$

$$P_{TOTAL} = 295\text{mW}$$

$$T_{J(MAX)} = T_{AMB} + \Theta_{JA} \cdot P_{LOSS} = 85^\circ\text{C} + (140^\circ\text{C/W}) \cdot 0.295\text{mW} = 126.3^\circ\text{C}$$

**Ordering Information**

Package	Voltage	Marking <sup>1</sup>	Part Number (Tape and Reel) <sup>2</sup>
TSOPJW-14	Adj (0.6V)	4UXYY	<b>AAT1185ITO-0.6-T1</b>



Skyworks Green™ products are compliant with all applicable legislation and are halogen-free.

For additional information, refer to *Skyworks*

*Definition of Green™*, document number

SQ04-0074.

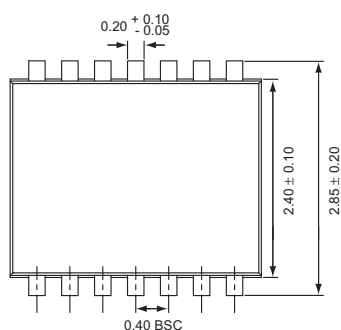
**Package Information****TSOPJW-14**

Top View

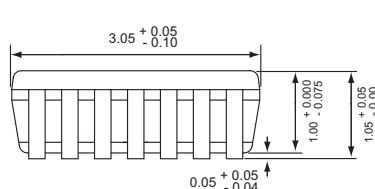

Side View

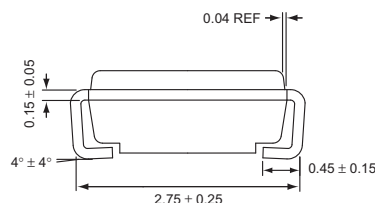

End View

All dimensions in millimeters.

1. XYY = assembly and date code.
2. Sample stock is generally held on part numbers listed in **BOLD**.

Copyright © 2012 Skyworks Solutions, Inc. All Rights Reserved.

Information in this document is provided in connection with Skyworks Solutions, Inc. ("Skyworks") products or services. These materials, including the information contained herein, are provided by Skyworks as a service to its customers and may be used for informational purposes only by the customer. Skyworks assumes no responsibility for errors or omissions in these materials or the information contained herein. Skyworks may change its documentation, products, services, specifications or product descriptions at any time, without notice. Skyworks makes no commitment to update the materials or information and shall have no responsibility whatsoever for conflicts, incompatibilities, or other difficulties arising from any future changes.

No license, whether express, implied, by estoppel or otherwise, is granted to any intellectual property rights by this document. Skyworks assumes no liability for any materials, products or information provided hereunder, including the sale, distribution, reproduction or use of Skyworks products, information or materials, except as may be provided in Skyworks Terms and Conditions of Sale.

THE MATERIALS, PRODUCTS AND INFORMATION ARE PROVIDED "AS IS" WITHOUT WARRANTY OF ANY KIND, WHETHER EXPRESS, IMPLIED, STATUTORY, OR OTHERWISE, INCLUDING FITNESS FOR A PARTICULAR PURPOSE OR USE, MERCHANTABILITY, PERFORMANCE, QUALITY OR NON-INFRINGEMENT OF ANY INTELLECTUAL PROPERTY RIGHT; ALL SUCH WARRANTIES ARE HEREBY EXPRESSLY DISCLAIMED. SKYWORKS DOES NOT WARRANT THE ACCURACY OR COMPLETENESS OF THE INFORMATION, TEXT, GRAPHICS OR OTHER ITEMS CONTAINED WITHIN THESE MATERIALS. SKYWORKS SHALL NOT BE LIABLE FOR ANY DAMAGES, INCLUDING BUT NOT LIMITED TO ANY SPECIAL, INDIRECT, INCIDENTAL, STATUTORY, OR CONSEQUENTIAL DAMAGES, INCLUDING WITHOUT LIMITATION, LOST REVENUES OR LOST PROFITS THAT MAY RESULT FROM THE USE OF THE MATERIALS OR INFORMATION, WHETHER OR NOT THE RECIPIENT OF MATERIALS HAS BEEN ADVISED OF THE POSSIBILITY OF SUCH DAMAGE.

Skyworks products are not intended for use in medical, lifesaving or life-sustaining applications, or other equipment in which the failure of the Skyworks products could lead to personal injury, death, physical or environmental damage. Skyworks customers using or selling Skyworks products for use in such applications do so at their own risk and agree to fully indemnify Skyworks for any damages resulting from such improper use or sale.

Customers are responsible for their products and applications using Skyworks products, which may deviate from published specifications as a result of design defects, errors, or operation of products outside of published parameters or design specifications. Customers should include design and operating safeguards to minimize these and other risks. Skyworks assumes no liability for applications assistance, customer product design, or damage to any equipment resulting from the use of Skyworks products outside of stated published specifications or parameters.

Skyworks, the Skyworks symbol, and "Breakthrough Simplicity" are trademarks or registered trademarks of Skyworks Solutions, Inc., in the United States and other countries. Third-party brands and names are for identification purposes only, and are the property of their respective owners. Additional information, including relevant terms and conditions, posted at [www.skyworksinc.com](http://www.skyworksinc.com), are incorporated by reference.